

Because the job always needs to be done.
Whenever. Wherever.

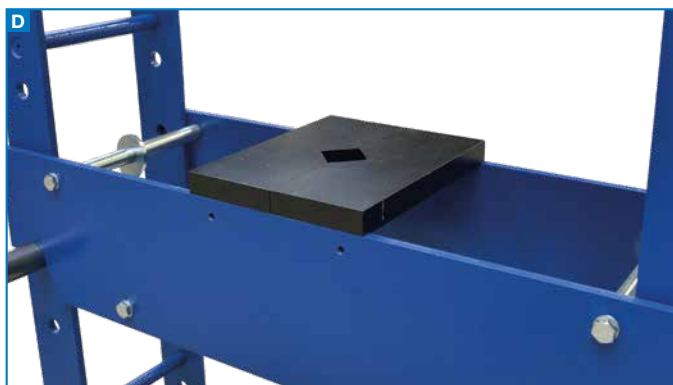

RÄUMPRESSE

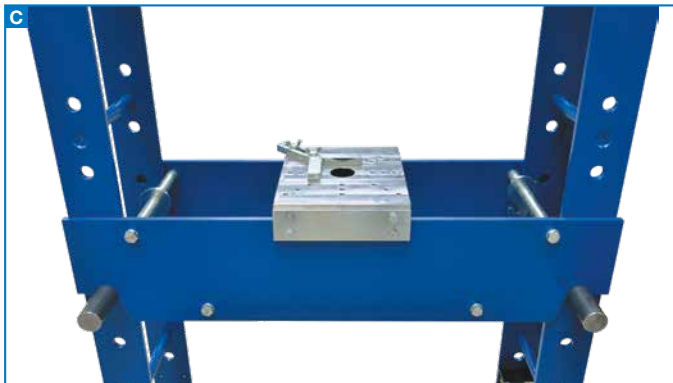

A Hydraulic unit equipped with a joystick for moving the piston up / down, pressure control valve and speed control valve.

B Integrated manometer.

C Table adjustment.

Optional accessories

D Set of V-blocks.

E Collection tray between feet.

F Collection tray for broach.



A Hydraulikeinheit ausgestattet mit einem Joystick zur Bewegung des Kolbens nach oben / unten, einem Druckregulierventil und einem Geschwindigkeitsregulierventil.

B Integriertes Manometer.

C Tischverstellung.

Sonderzubehör

D V-Block-Satz.

E Auffangwanne zwischen den Füßen.

F Auffangwanne für Räumwerkzeug.

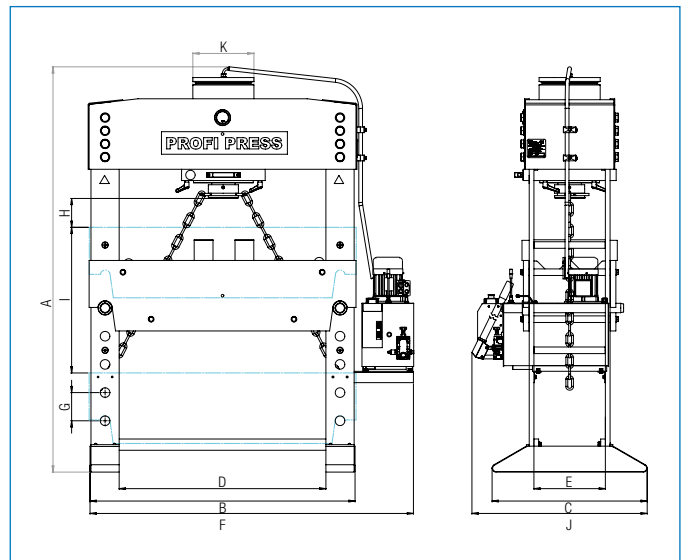

DIMENSIONS / ABMESSUNGEN [MM]

	15 TON
A	2300
B	820
C	494
D	650
E	200
F	1140
G	100
H	112
I	900
J	700
K	110